

LECTRODRYER

ADSORPTION TECHNOLOGY EXPERTS



TYPE BZ Compressed Air and Gas Dryers



Type BZ LECTRODRYER

No purge loss. No Blower. Continuous Low Dewpoints



The type BZ Lectrodryer is ideally suited for drying compressed air or gas. The unit is fully automatic, positive in operation and built for reliable and foolproof operation.

The BZ model is a dual tower, heat reactivated solid adsorption air dryer. Normal operating range for standard units is 40-150 PSIG. Units for 300 PSIG and higher working pressures are available.

The type BZ Lectrodryer is equipped with a split stream type closed-circuit reactivation system with the Lectrodryer proportioning valve to automatically control the reactivation flow through the desiccant bed on reactivation and return it to the inlet stream to be dried with no loss of air from the system. The unit is equipped with proportioning valve, external heater, water-cooled heat exchanger (innercooler), separator and condensate trap, and all necessary controls and instruments for fully automatic operation.

The adsorbers are reactivated by heating the flow of reactivating air to drive off moisture from the desiccant bed. The reactivating air is split from main stream for reactivation, then returned to the main stream without any waste.

Both adsorption and reactivation circuits operate at line pressure eliminating any damage to the desiccant from buildup or bleed-down pressure on the adsorbers.

The closed loop system eliminates waste or loss of flow and therefore, it can be used with explosive or expensive gases. The BZ type Lectrodryer is available for electric or steam reactivation in a wide range of standard sizes.

TYPICAL SPECIFICATIONS

Model	Length (Inches)	Width (Inches)	Height (Inches)	Weight (LBS)	Electric Reactivation Connected load/KVA	Average KW	Steam Reactivation lbs/hr Average	Cooling water/GPM	Standard Connections (inches)
BZ-225	60	30	90	1040	4.5	3.3	15	1-1/2	1-1/2
BZ-325	70	35	90	1520	7.5	5.6	22	2	1-1/2
BZ-600	90	40	130	2800	15	11.2	41	3-1/2	2
BZ-1000	80	48	130	4680	24	18	70	5-1/2	2 or 3
BZ-1500	80	50	120	7000	40	30	104	8-1/2	3
BZ-2000	100	60	120	9320	50	37.5	139	11	3 or 4
BZ-3000	130	70	106	14080	70	52.5	210	16	4 or 6
BZ-4000	150	75	115	18640	100	75	278	23	6
BZ-5000	155	75	118	23280	120	90	345	29	6
BZ-6500	150	80	130	30400	150	112	450	38	6 or 8
BZ-8000	160	85	130	37200	190	142	553	45	8
BZ-12000	180	100	140	50000	280	210	829	68	8 or 10
BZ-20000	214	112	140	60000	460	345	1384	113	10

1. Steam consumption is based on 150 PSIG saturated steam.

2. Utility requirements are based on a full load condition.

3. Utility requirements may be reduced by utilizing the Reactivation Termination and Lectrolod Demand Cycle Control options.



Typical BZ LECTRODRYER

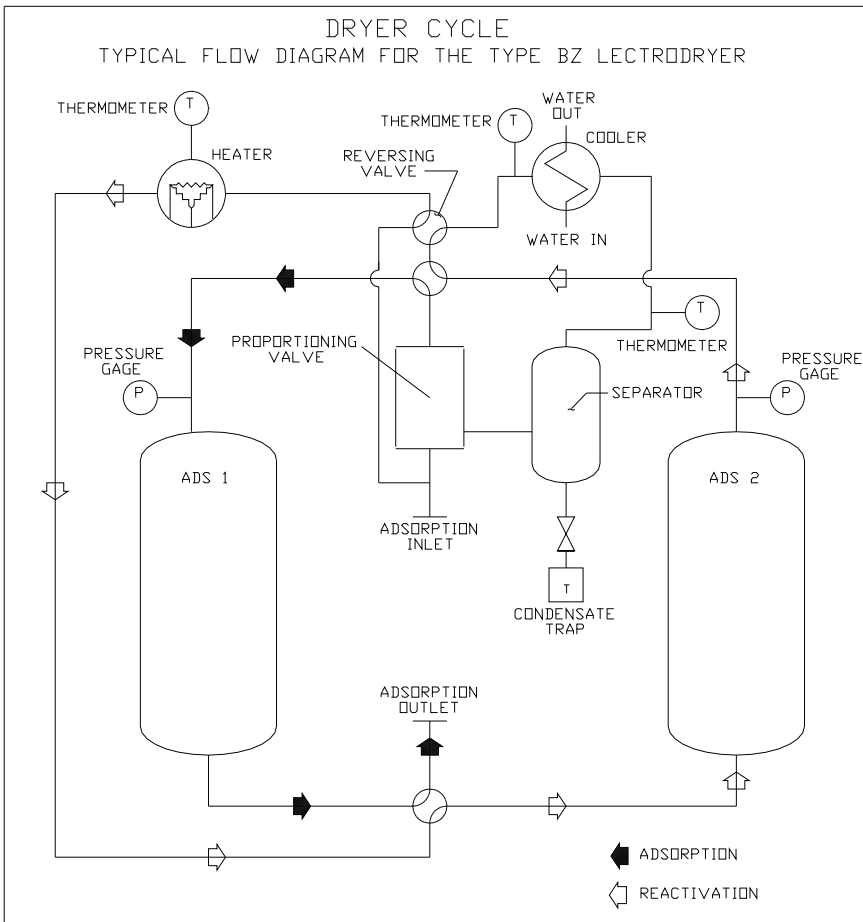

CONTROLS

- Main valves are operated by a pneumatic actuator with separate filter, lubricator and valve.
- Steam flow is controlled by a valve providing reliable, positive closing at high temperatures.
- A thermostat is provided for protections of electrical heaters.

INSTRUMENTATION

All Type BZ Lectrodryers are equipped with a control panel with control switch, pressure gages, indicating lights, and relief valves.

STANDARD FEATURES

- Thermometers indicating input and output reactivation temperatures.
- Adjustable cycle timer.
- ASME code vessels where necessary.
- Fill and drain connections.
- Lubricated plug valves.
- NEMA 1 electrical enclosures.

OPTIONAL FEATURES

- Non lubricated valves
- NEMA 4, 12, and 7 electrical enclosures
- Switch failure alarm
- Heater failure alarm
- High-temperature alarm
- High-humidity alarm
- Lectrolod Demand Cycle Control

AUTOMATIC OPERATION

The type BZ Lectrodryer is a fully automatic unit supplying a continuous flow of dry air or gas. It requires very little maintenance, except for occasional lubrication.

The BZ operates on a eight-hour NEMA cycle with four hours adsorption, three hours heating, and one hour cooling. The unit automatically switches adsorbers as the cycle progresses. The reactivation flow is in an upward direction through the desiccant bed during the heating period. The reversing valve then switches and during the cooling period the bed is cooled in a downward direction. Reversing of the flow promotes lower dewpoints allowing the BZ to provide higher quality without the higher cost of a specialized desiccant.



LECTRODRYER HAS THE SOLUTION FOR ALL COMPRESSED AIR AND GAS DRYING PROBLEMS

Lectrodryer offers a complete range of drying and purification equipment:
For atmospheric or high pressure conditions
For very small or very large air volumes
For air, gases, and certain organic fluids

Regenerative Adsorption Dryer

Typical applications:

Drying compressed air for instruments; purging of refrigeration coils, compressors, and systems; drying air for ozone generators; vacuum-breaking operations controlled atmosphere gas



Features:

Carbon steel pressure vessels with ASME Code (where applicable) for up to 150 PSIG Stainless steel perforated metal desiccant support and inlet flow diffuser, sheathed or non sheathed heating element in which each adsorber vessel with thermostatic over temperature protection in the heater bundle, two 4-way lubricated plug valves with air piston operator and solenoid valve controls, thermal pressure relief valves, pressure gages, dial thermometer in the purge outlet, 110 volt controls and NEMA 1 electrical enclosures.

Optional Features:

Special controls and electrical enclosures.

Refrigeration-Type Industrial Gas Dryer

Typical Application:

Low pressure situations for controlling atmospheric gases.

Features:

Power-on light, high temperature warning light, on/off switch, refrigeration analyzer gage, gas-out gage, gas-in temperature gage, low suction pressure cut-out, high head pressure cut-out, hot gas bypass capacity control, start push button pump down shut off cycle, oil pressure control, and suction accumulator.



Optional Features:

Special control and electrical enclosures.

Lectrodryer Filters

The Lectrodryer type SF and type F filters provide high efficiency filtration with ten sizes available in each type for flows to 8400 SCFM, larger sizes available on application. Both types have a high level filter efficiency of 99.985% retention (0.015 DOP penetration) for filtration to a 0.3 micron



Lube Oil / Air Tanks

Lectrobreather tank vent dryers prevent atmospheric moisture from entering storage during "breathing" due to ambient temperature changes and draining periods. Valuable oils and chemical solutions remain free of water contamination.



CONTINUING THE TRADITION OF QUALITY AND SERVICE SINCE 1932

LECTRODRYER

P.O. Box 2500, Richmond, KY 40476-2602 U.S.A.
Phone: (859) 624-2091 Fax: (859) 623-2436
Website: www.lectrodryer.com E-mail: info@lectrodryer.com